

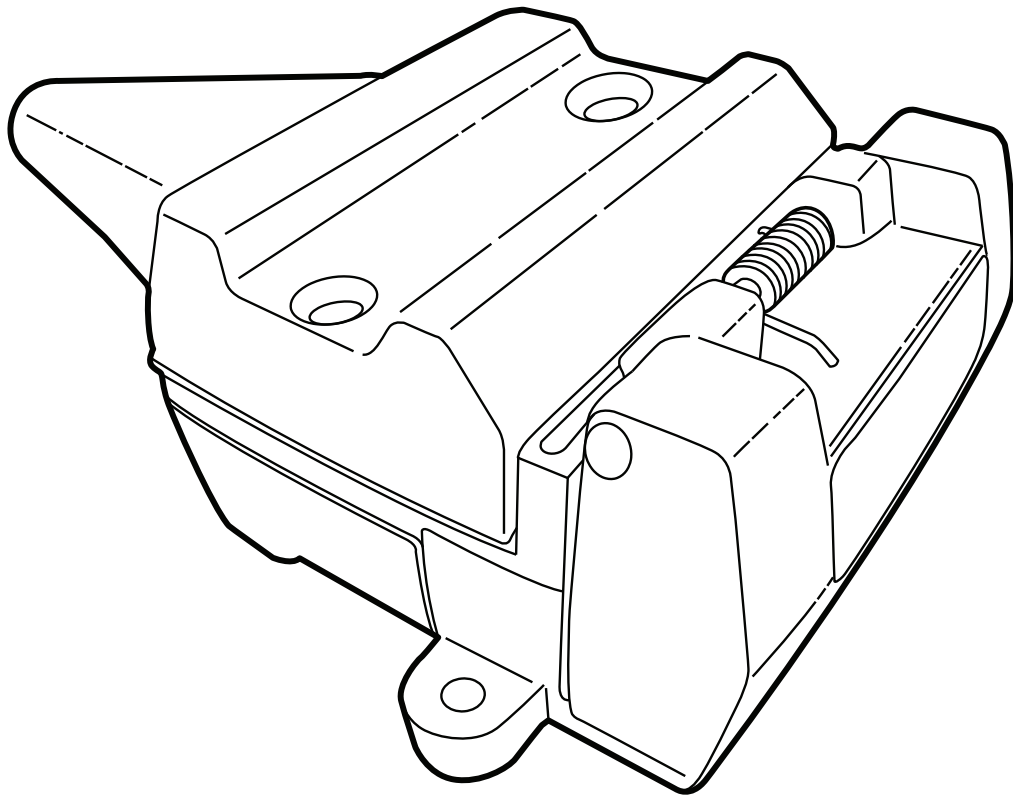

CARAVAN

—
Various Models with 12-pin



TOW VEHICLE REQUIREMENTS INSTRUCTIONS

FI Doc No: JAY-12PIN-FI - Issue: 10 - 06/09/21



GENERAL NOTES

- Read through the fitting instructions before installation.
- Always install the accessory following the fitting instructions. Failure to do so may cause damage to the vehicle or the accessory.
- Ensure all recyclable discarded vehicle accessory components and packaging are recycled following local recycling regulations.
- It is always recommended that this accessory is fitted by a qualified technician.
- Safely store and protect any removed vehicle components.
- Remove all metal swarf and dust from all vehicle surfaces if surface is used for accessory installation.

SAFETY NOTES

- Check that all work practices comply with safety standards.
- Please wear appropriate clothing and use safety equipment.

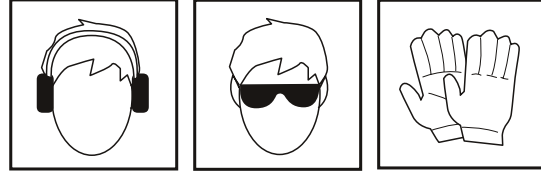

FITTING TIME



30 minutes

PARTS SUPPLIED

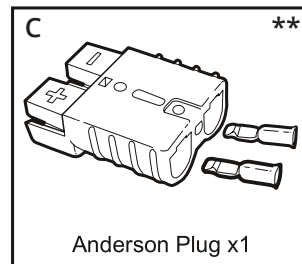
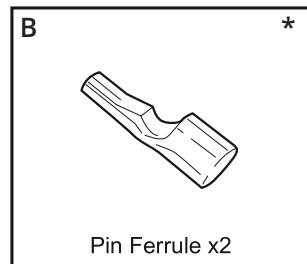
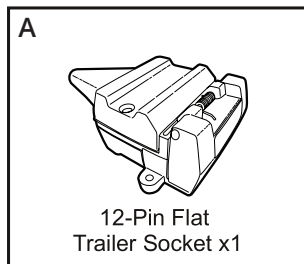

TOOLS AND MATERIALS REQUIRED

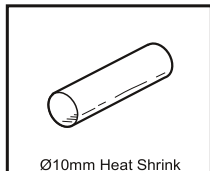
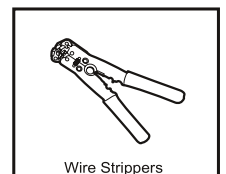
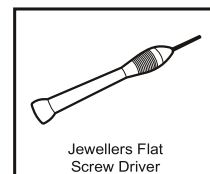
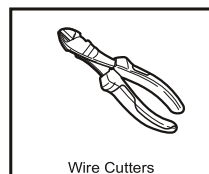
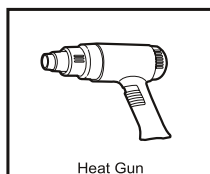
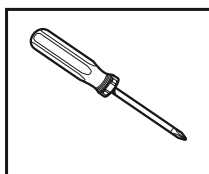

- Items marked (*) are not required for Silverline.
- Items marked (**) are only supplied with Silverline.

All Jayco caravans utilise a flat plug manufactured to Australian Standard AS4177.5-2004.

The following instruction is to ensure adequate wire sizes are used to support van electrical requirements, minimising voltage drop and resistance in the circuits.

STANDARD
(VIEW WITH LID OPEN)



Below is a table listing each pin, what circuit to connect to on the towing vehicle, and the minimum wire size to be used:

Pin#	Function	Colour	Min Wire Size (T)		Special Connection Instructions
			mm ²	AWG	
1	Left Indicator	Yellow	1.25	16	-
2	+12V Supply from Battery	Black	3.0	12	Connect directly to vehicle battery with a 30A fast acting fuse
3	Ground	White	3.0	12	Connect to vehicle chassis ground point. Do not connect to trailer harness ground wire. Do not connect directly to negative battery terminal
4	Right Indicator	Green	1.25	16	-
5	Electric Brakes	Blue	2.0	14	Connect to Electric Brake Controller
6	Stop Lamp	Red	1.25	16	-
7	Tail Lamps	Brown	1.25	16	-
8	Not Connected	-	-	-	-
9	Fridge +12V Supply (direct from battery)	Pink	10.0	8	Connect direct to vehicle battery positive terminal with a 30A fast acting fuse
10	Fridge Ground (direct from battery)	White	10.0	8	Connect directly to vehicle battery negative terminal or vehicle chassis ground point
11	Not Connected	-	-	-	-
12	Not Connected	-	-	-	-

(T) - mm² refers to the cross-sectional area of the copper in the wire.

Wire labelled as “6mm Auto” (for example) may not have 6mm² cross-sectional area.



It is critical that the correct wire size is used for each wire, otherwise damage could occur to the vehicle and caravan wiring. Consult a qualified auto electrician if you are unsure.

STEP 1

Pins 1, 2, 4, 5, 6 & 7 will likely be connected through the towing vehicle's existing trailer wiring, and the wires can simply be removed from the existing vehicle trailer socket and housed in the correct pins on the supplied 12-pin socket.

Note: Consult your vehicle dealer or a qualified auto electrician if you are unsure.

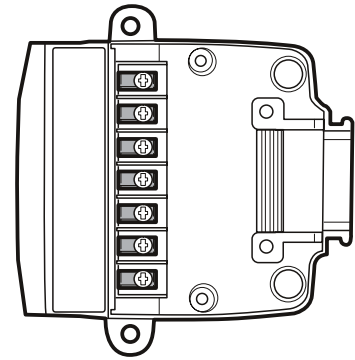

STEP 2

Pin 2 may be connected to the towing vehicle's reverse signal through the existing vehicle trailer wiring. If so, remove this wire from the existing vehicle trailer socket and tape it back. Then connect a new wire with a 30A fuse directly from the vehicle battery positive terminal to pin 2 on the supplied 12-pin socket (refer to table above for minimum wire size required)

Note: Do not connect Pin 2 to any other existing power circuit on the vehicle. This could cause damage to the vehicle wiring. Consult your vehicle dealer or a qualified auto electrician if you are unsure.

Note: A fast acting 30A fuse must be used and mounted as close to the battery as possible.

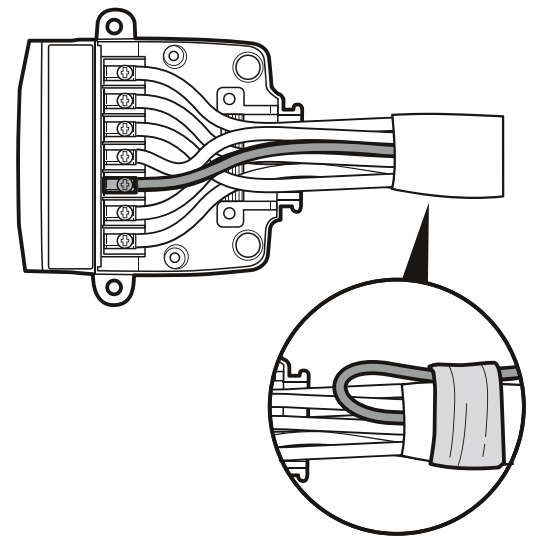

STEP 3

Pin 2 may be connected to the towing vehicle's reverse signal through the existing vehicle trailer wiring. If so, remove this wire from the existing vehicle trailer socket and tape it back. Then connect a new wire with a 30A fuse directly from the vehicle battery positive terminal to pin 2 on the supplied 12-pin socket (refer to table above for minimum wire size required)

Note: Do not connect Pin 2 to any other existing power circuit on the vehicle. This could cause damage to the vehicle wiring. Consult your vehicle dealer or a qualified auto electrician if you are unsure.

Note: A fast acting 30A fuse must be used and mounted as close to the battery as possible.

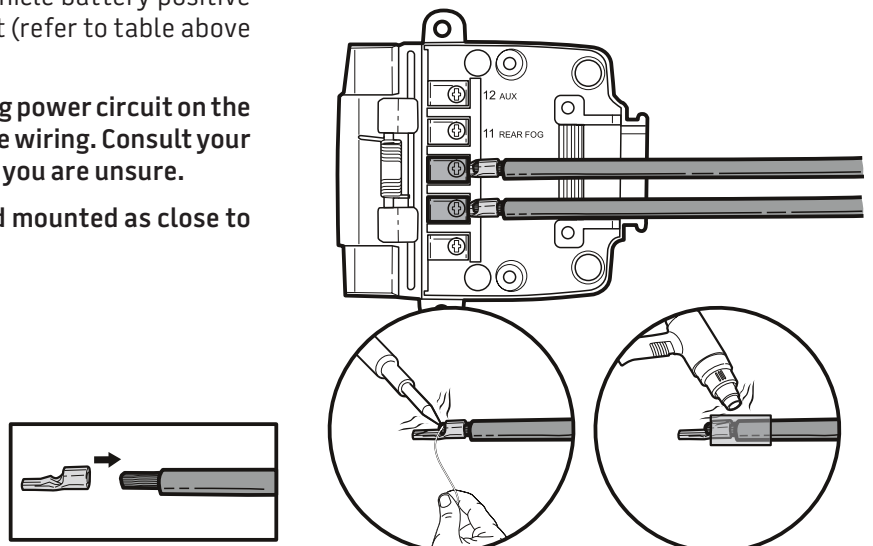

STEP 4

- It is recommended that a voltage-sensing battery isolator relay is also installed in series with both the fridge +12V battery supply on Pin 9 and the standard 12V supply on Pin 2 in order to prevent the caravan from draining the towing vehicle battery. Both circuits can be connected to the battery through the same isolator relay as long as it is rated to at least 60A. The relay should be fitted and connected as close to the vehicle battery as possible – refer to the relay manufacturer instructions for exact installation requirements.
- **Note: Consult your vehicle dealer or a qualified auto electrician if you are unsure.**

STEP 5

- Connect the caravan to the towing vehicle.
- Test all caravan lamps and other electrical devices for correct operation.

SILVERLINE JOURNEY

SILVERLINE/JOURNEY WITH 360° CAMERA SYSTEM (VIEW WITH LID OPEN)

ANDERSON TERMINAL

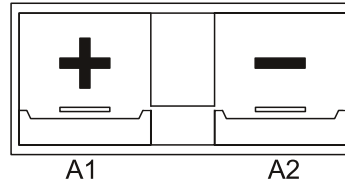

Below is a table listing each pin, what circuit to connect to on the towing vehicle, and the minimum wire size to be used:

Pin#	Function	Colour	Min Wire Size (T)		Special Connection Instructions
			2	AWG	
1	Left Indicator	Yellow	1.25	16	-
2	Reverse	Black	1.25	16	-
3	Ground	White	3.0	12	Connect to vehicle chassis ground point. Do not connect to trailer harness ground wire. Do not connect directly to negative battery terminal
4	Right Indicator	Green	1.25	16	-
5	Electric Brakes	Blue	2.0	14	Connect to Electric Brake Controller
6	Stop Lamp	Red	1.25	16	-
7	Tail Lamps	Brown	1.25	16	-
8	+12V Supply from Battery	Orange	5.0	10	Connect direct to vehicle battery positive terminal with a 30A fast acting fuse
9	Not Connected	-	-	-	-
10	Ground	White	5.0	10	Connect directly to vehicle battery negative terminal or vehicle chassis ground point
11	Not Connected	-	-	-	-
12	Not Connected	-	-	-	-
A1	Fridge +12V Supply (direct from battery)	Red		7	Connect direct to vehicle battery with a 30A fast acting fuse
A2	Fridge Ground (direct from battery)	Black		7	Connect directly to vehicle battery negative terminal or vehicle chassis ground point

(T) - mm² refers to the cross-sectional area of the copper in the wire.

Wire labelled as "6mm Auto" (for example) may not have 6mm² cross-sectional area.



It is critical that the correct wire size is used for each wire, otherwise damage could occur to the vehicle and caravan wiring. Consult a qualified auto electrician if you are unsure.

STEP 1

Pins 1, 2, 3, 4, 5, 6 & 7 will likely be connected through the towing vehicle's existing trailer wiring, and the wires can simply be removed from the existing vehicle trailer socket and housed in the correct pins on the supplied 12-pin socket.

Note: Consult your vehicle dealer or a qualified auto electrician if you are unsure.

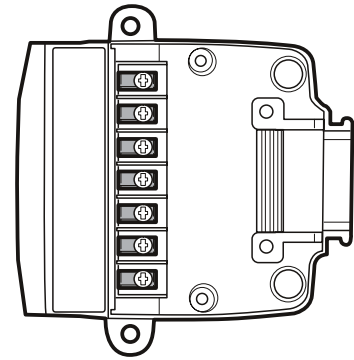

STEP 2

Pins 8 & 10 must be connected directly to the towing vehicle battery, refer to the table on page 9 above for minimum wire size required. Pin 8 wire should be fused with a 30A fuse as close to the vehicle battery as possible.

Note: Do not connect Pin 8 to any other existing power circuit on the vehicle. This could cause damage to the vehicle wiring. Consult your vehicle dealer or a qualified auto electrician if you are unsure.

Note: A fast acting 30A fuse must be used and mounted as close to the battery as possible.

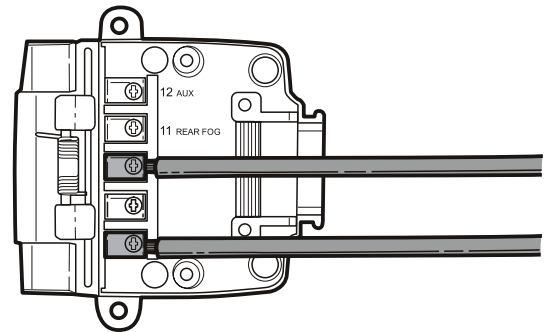

STEP 3

The Anderson plug pins must be connected directly to the towing vehicle battery, refer to table on page 6 above for minimum wire size required. The (+) wire should be fused with a 30A fuse as close to the vehicle battery as possible. At the Anderson plug end, the pins must be crimped and soldered onto the wires before fitting the wires to the Anderson plug.

Note: Do not connect the positive '+' to any other existing power circuit on the vehicle. This could cause damage to the vehicle wiring. Consult your vehicle dealer or a qualified auto electrician if you are unsure.

Note: A fast acting 30A fuse must be used and mounted as close to the battery as possible.

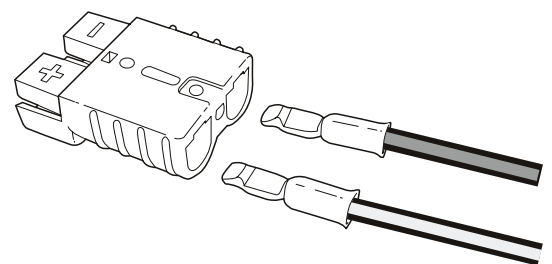

STEP 4

It is recommended that a voltage-sensing battery isolator relay is also installed in series with both the fridge +12V battery supply on Anderson Plug and the standard 12V supply on Pin 8 in order to prevent the caravan from draining the towing vehicle battery. Both circuits can be connected to the battery through the same isolator relay as long as it is rated to at least 60A. The relay should be fitted and connected as close to the vehicle battery as possible – refer to the relay manufacturer instructions for exact installation requirements.

Note: Consult your vehicle dealer or a qualified auto electrician if you are unsure.

STEP 5

Connect the caravan to the towing vehicle.

Test all caravan lamps and other electrical devices for correct operation.

CROSSTRAK CROSSHAUL J-POD

CROSSTRAK/CROSSHAUL/J-POD (VIEW WITH LID OPEN)



Below is a table listing each pin, what circuit to connect to on the towing vehicle, and the minimum wire size to be used:

Pin#	Function	Colour	Min Wire Size (T)		Special Connection Instructions
			2	AWG	
1	Left Indicator	Yellow	1.25	16	-
2	Reverse Signal	Black	1.25	16	-
3	Ground	White	3.0	12	Connect to vehicle chassis ground point. Do not connect to trailer harness ground wire. Do not connect directly to negative battery terminal
4	Right Indicator	Green	1.25	16	-
5	Electric Brakes	Blue	2.0	14	Connect to Electric Brake Controller
6	Stop Lamp	Red	1.25	16	-
7	Tail Lamps	Brown	1.25	16	-
8	+12V Auxiliary Supply	Orange	5.0	10	Connect direct to vehicle battery positive terminal with a 30A fast acting fuse
9	Not Connected	-	-	-	-
10	Ground	White	5.0	10	Connect directly to vehicle battery negative terminal or vehicle chassis ground point
11	Not Connected	-	-	-	-
12	Not Connected	-	-	-	-

(T) - mm² refers to the cross-sectional area of the copper in the wire.

Wire labelled as "6mm Auto" (for example) may not have 6mm² cross-sectional area.



It is critical that the correct wire size is used for each wire, otherwise damage could occur to the vehicle and caravan wiring. Consult a qualified auto electrician if you are unsure.

STEP 1

Pins 1, 2, 4, 5, 6 & 7 will likely be connected through the towing vehicle's existing trailer wiring, and the wires can simply be removed from the existing vehicle trailer socket and housed in the correct pins on the supplied 12-pin socket.

Note: Consult your vehicle dealer or a qualified auto electrician if you are unsure.

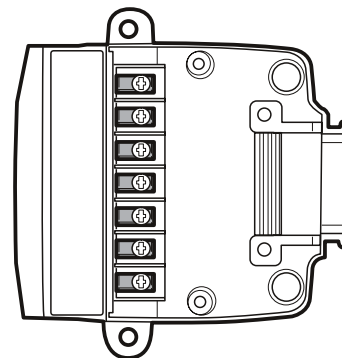

STEP 2

Pins 8 must be connected directly to the towing vehicle battery, refer to the table on the previous page for minimum wire size required. Pin 8 must be fused with a 30A fuse as close to the vehicle battery as possible. Pin 10 can be connected directly to the towing vehicle battery negative terminal or the towing vehicle chassis.

Note: Do not connect Pin 8 to any other existing power circuit on the vehicle. This could cause damage to the vehicle wiring. Consult your vehicle dealer or a qualified auto electrician if you are unsure.

Note: A fast acting 30A fuse must be used and mounted as close to the battery as possible.

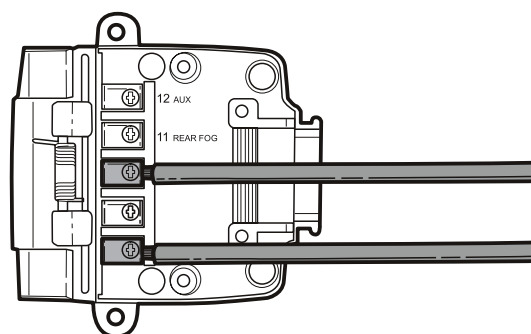

STEP 3

It is recommended that a voltage-sensing battery isolator relay is also installed in series with 12V supply on Pin 8 in order to prevent the caravan from draining the towing vehicle battery. The relay should be fitted and connected as close to the vehicle battery as possible – refer to the relay manufacturer instructions for exact installation requirements.

Note: Consult your vehicle dealer or a qualified auto electrician if you are unsure.

STEP 3

Connect the caravan to the towing vehicle.

Test all caravan lamps and other electrical devices for correct operation.